

# OVERVIEW

2026



cimtas | steel



cimtas | pipe



cimtas | shipyard



cimtas | ningbo



cimtas | machining



**400,000 t**  
CAPACITY

**5,000**  
EMPLOYEES

**ZERO**  
INCIDENT POLICY

ÇİMTAŞ GROUP, a subsidiary of ENKA, having with an aggregated annual capacity of 400,000 tons, provides engineering, procurement, fabrication, machining, modularization, erection and installation services to the leading customers of construction, power, oil, gas and chemicals, renewable industries.

# COMPANY STRUCTURE

**ENKA**



**cimtas | steel**



**cimtas | pipe**

**cimtas | shipyard**

**cimtas | ningbo**

**cimtas | machining**

More than **590** Projects in **60** Countries  
More than **67 Billion USD** Historical Contract Value

**46<sup>th</sup>** @ ENR Top 250 International Contractors List - 2025  
More than **25,000** Employees

**ENKA**



OIL, GAS & PETROCHEMICALS



POWER PLANTS



INFRASTRUCTURE



BUILDING WORKS



**80,000 t** CAPACITY **ZERO** INCIDENT POLICY

 Gemlik / Türkiye  
160,000 m<sup>2</sup>

ÇİMTAŞ STEEL, the flagship company of ÇİMTAŞ GROUP, with its multifunctional yard, offers comprehensive solutions in structural steel, pressure vessels, renewable energy structures, and offshore / subsea projects by providing engineering, welded fabrication, modularization, and installation services.

# cimtas | pipe



**4 Million DIA"**  
SPOOL FABRICATION  
CAPACITY

**100,000 t**  
LSAW PIPE  
CAPACITY

**6,000 t**  
FITTINGS  
CAPACITY

  
Gemlik FTZ / Türkiye  
120,000 m<sup>2</sup>

CIMTAS PIPE is a market-leading company providing engineering, procurement, manufacturing of LSAW pipes and fittings, fabrication of pipe spools for power, oil, gas and nuclear industry with the best in class vision.

# cimtas | shipyard



**80,000 t**  
FABRICATION  
CAPACITY

**70,000 t**  
ASSEMBLY  
CAPACITY

  
Kocaeli FTZ / Türkiye  
270,000 m<sup>2</sup>

ÇİMTAŞ SHIPYARD fabricates structural steel, steel wind towers, offshore & subsea structures, modules and sea vessels at its facility having vast assembly yards and a self-quay for direct sea transportation.

cimtas | ningbo



**1.5 Million DIA"**  
SPOOL FABRICATION  
CAPACITY

**6,000 t**  
SKID & MODULES  
ASSEMBLY CAPACITY

 Ningbo FTZ / China  
56,000 m<sup>2</sup>

CIMTAS NINGBO provides process & OEM piping, skid-mounted process assemblies and modularization solutions to power, oil & gas and petrochemical industries.

# cimtas | machining



**7** NADCAP  
**5** MERIT  
**300,000 HOURS**  
5 AXIS MACHINING

  
Gemlik FTZ / Türkiye  
13,000 m<sup>2</sup>

Çimtaş Machining is a high-precision manufacturing company partnering with aerospace and power OEMs and tech giants, executing strategic programs and leveraging advanced manufacturing capabilities to advance next-generation platforms.



STRUCTURAL  
STEEL

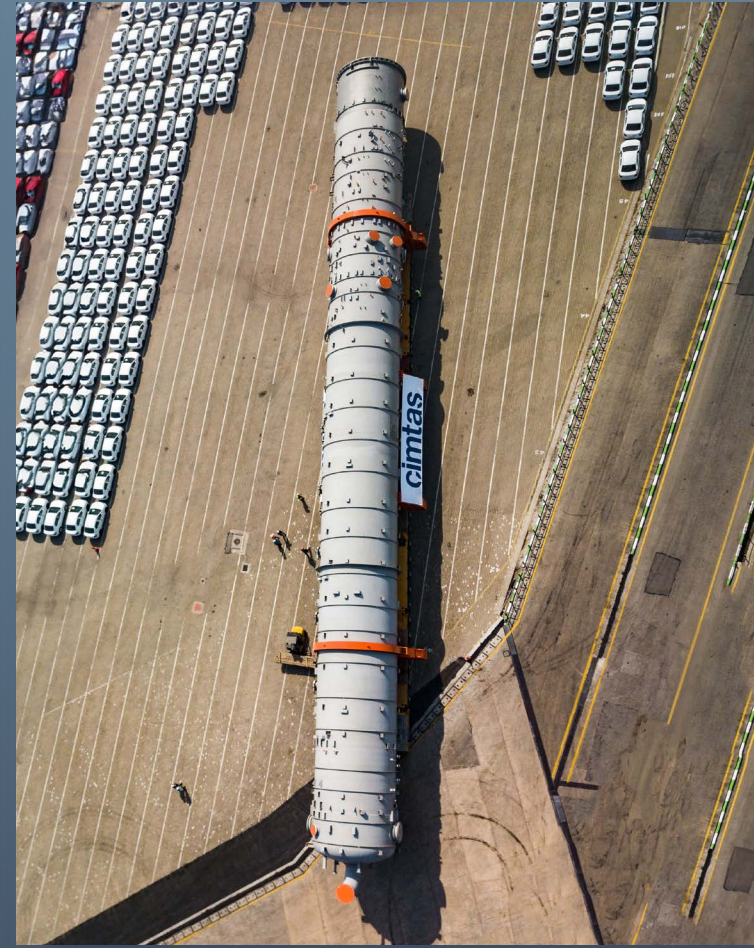

PRESSURIZED  
EQUIPMENT



STEEL  
WIND TOWERS

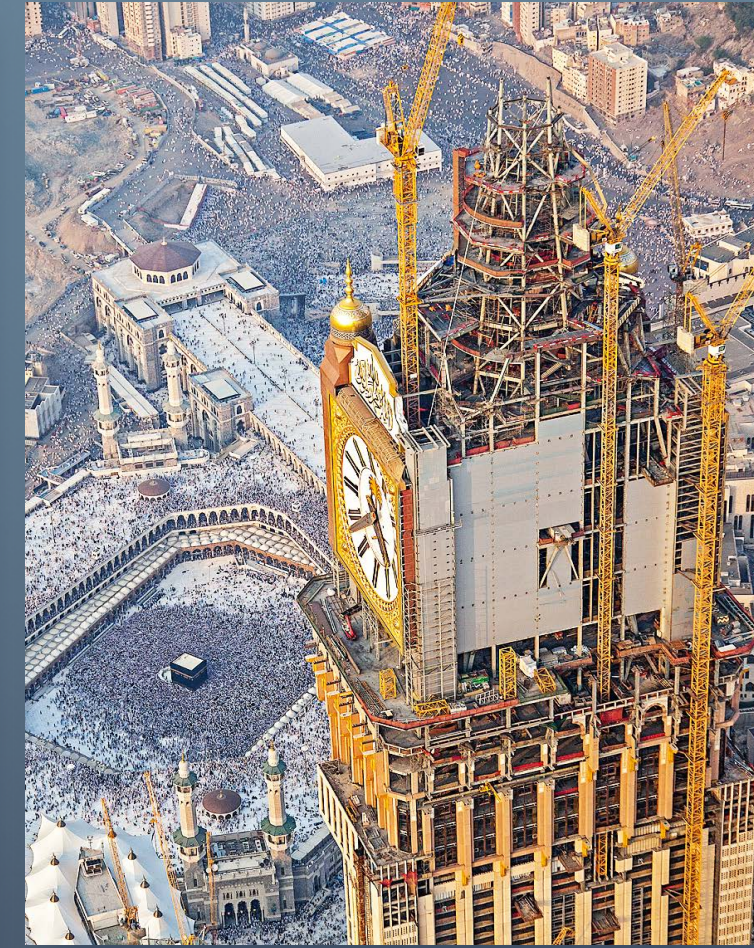

INSTALLATION



OFFSHORE  
STRUCTURES



MODULARIZATION



SHIPBUILDING &  
POWERSHIPS



SPOOLS



FITTINGS



LSAW PIPES



GAS TURBINE  
COMPONENTS

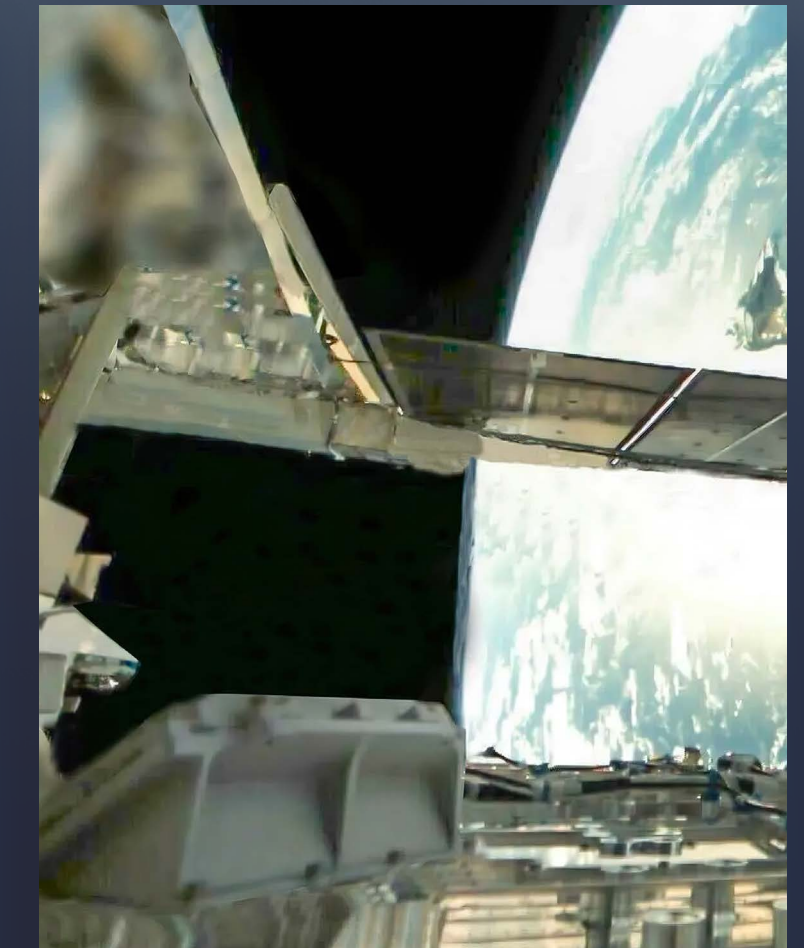

SATELLITE  
COMPONENTS



HIGH RISES



STEEL BRIDGES



POWER, OIL & GAS PLANTS



INDUSTRIAL PLANTS



AIRPORTS



STADIUMS



TCO FUTURE GROWTH PROJECT

Kazakhstan



ICA FLUOR PROJECT

Mexico



ANGOLA LNG

Angola



PEMEX PRESSURE VESSELS

Mexico



8 m DIAMETER



300 t SECTION WEIGHT



35 m LENGTH



25 COUNTRIES



İZMİR-GEBZE-ADAPAZARI CCPP 3,850 MW

Türkiye



WALSUM COAL FIRED POWER PLANT 800 MW

Germany



RIJNMOND CCPP 770 MW

The Netherlands



SECOND GENERATION PROJECT 25 Million t

Kazakhstan



SAKARYA GAS FIELD DEVELOPMENT PROJECT



Türkiye



SAKARYA GAS FIELD DEVELOPMENT PROJECT



Türkiye

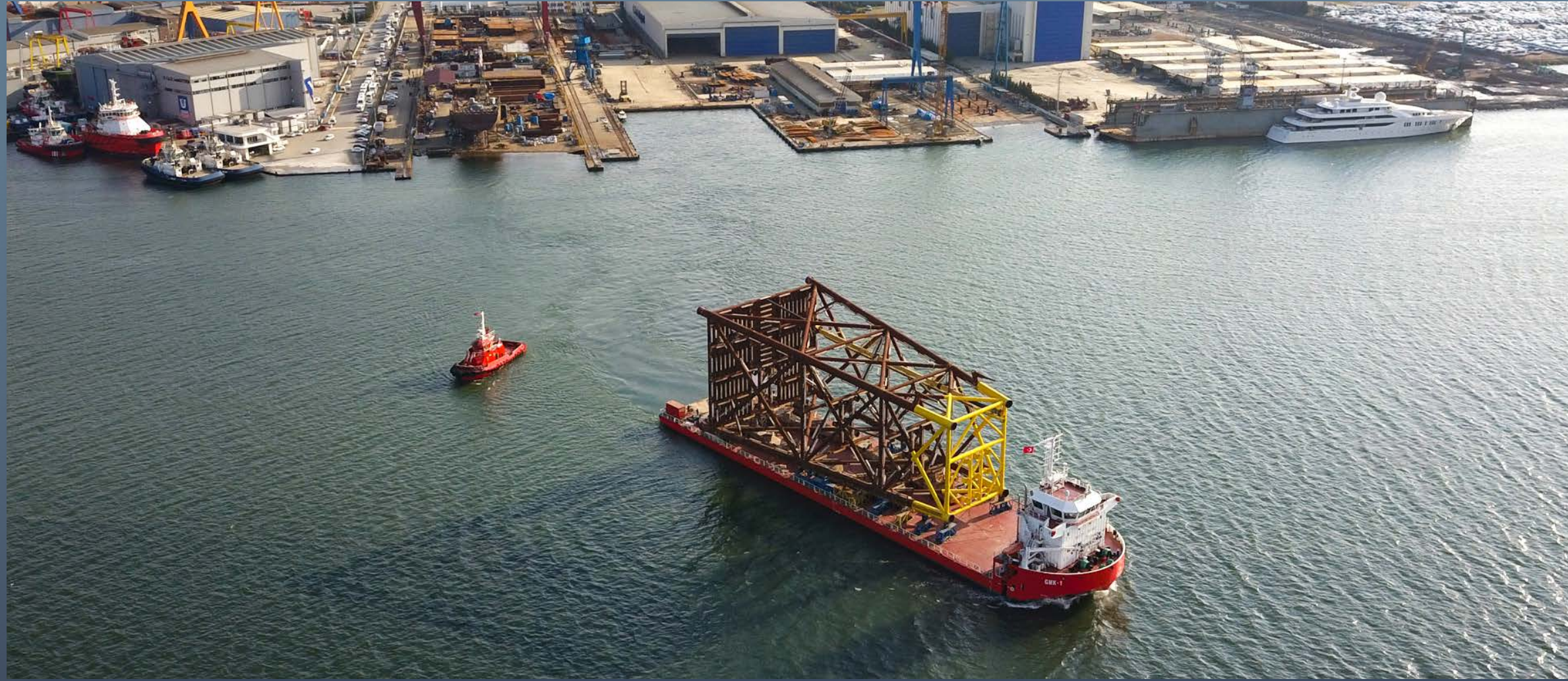

KUZEY MARMARA UNDERGROUND GAS STORAGE EXPANSION PROJECT

Türkiye



STINGER SECTION PROJECT

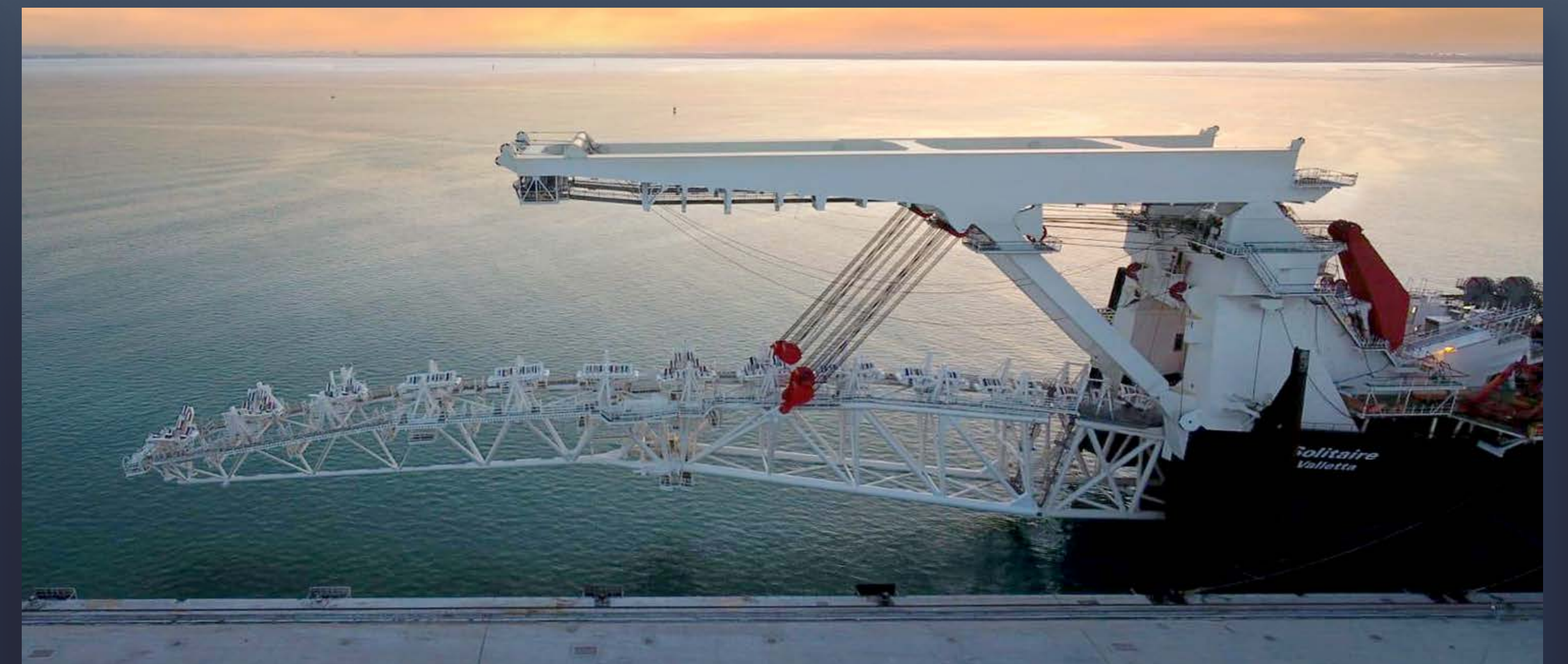

The Netherlands



WEST QURNA PROJECT



Iraq SECOND GENERATION PROJECT

Kazakhstan



PETROBRAZI PLANT CCR

Romania



POLY BED HYDROGEN PURIFICATION SKID

Russia



KPS6 POWERSHIP

Türkiye



KPS9 POWERSHIP

Türkiye

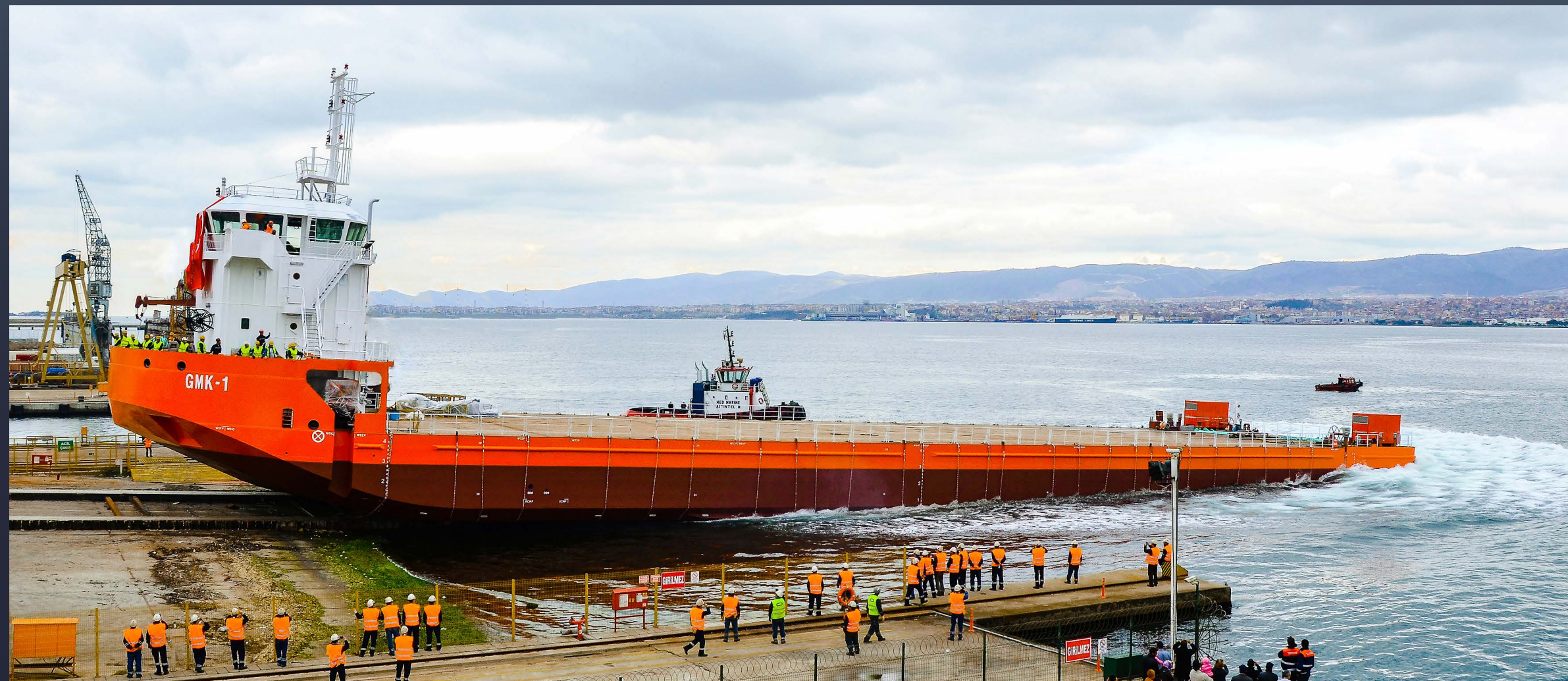

GMK-1 DYNAMIC POSITIONING SERVICE VESSEL

Türkiye



SOLEY-4

Türkiye

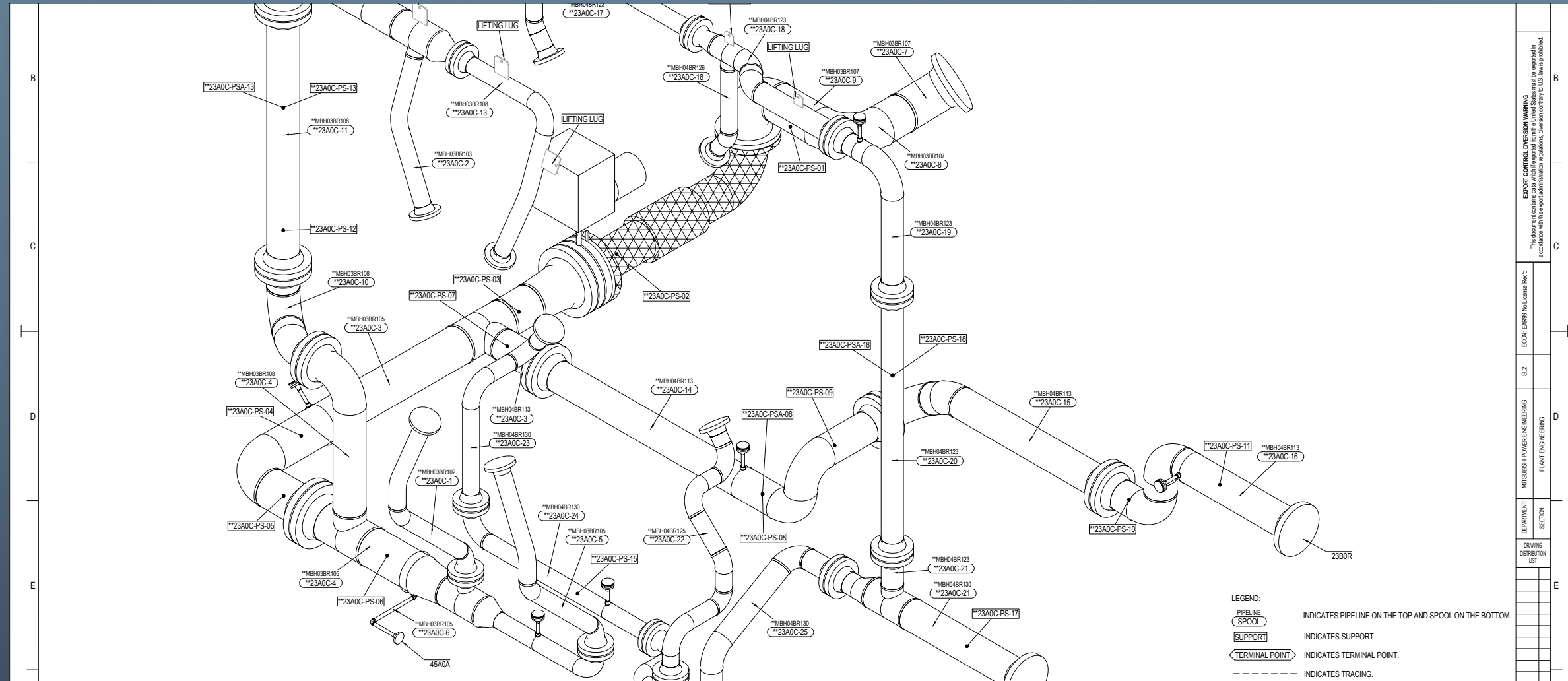

ENGINEERING

FABRICATION



PACKAGING

TRANSPORTATION



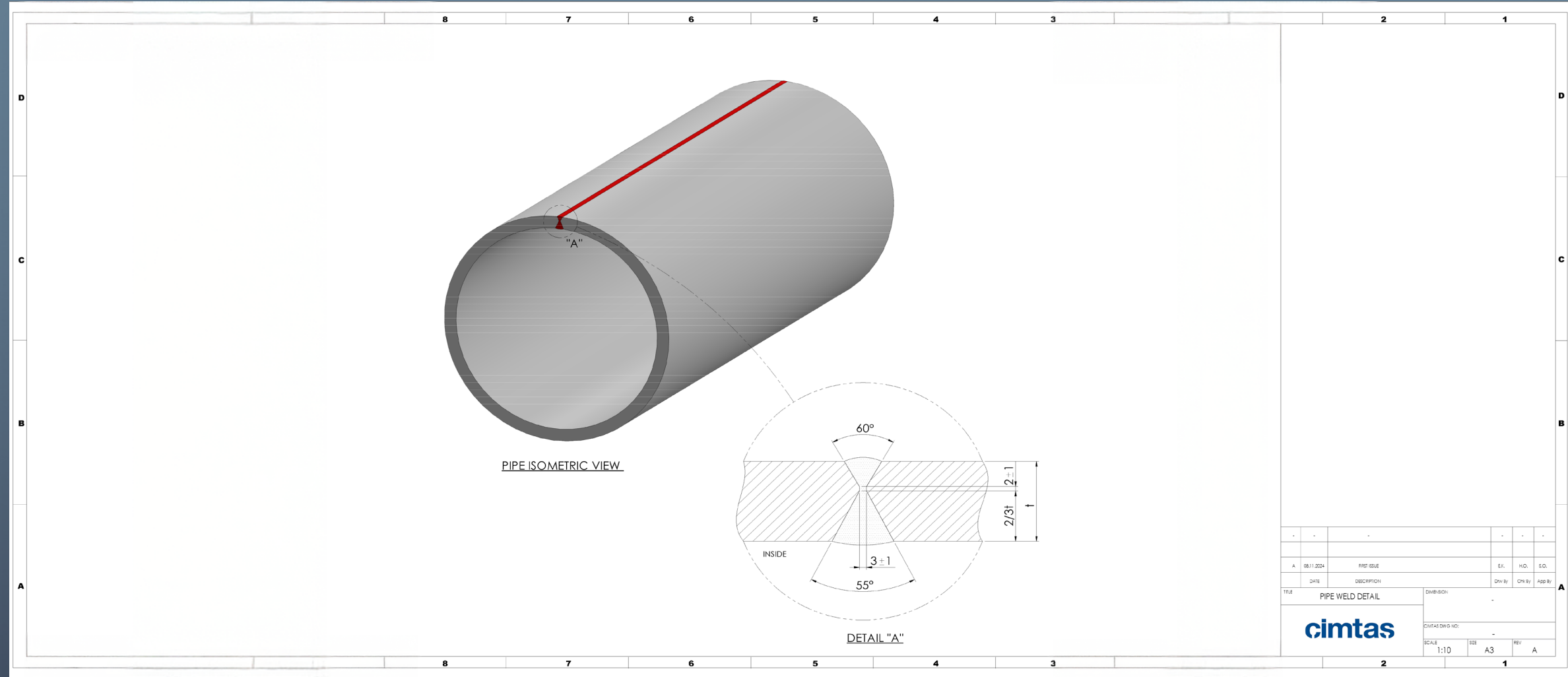

ENGINEERING

FABRICATION



JCO FORMING

HEAT TREATMENT



IFOP STAR REFINERY

Türkiye



AUSTRALIA PACIFIC LNG

Australia

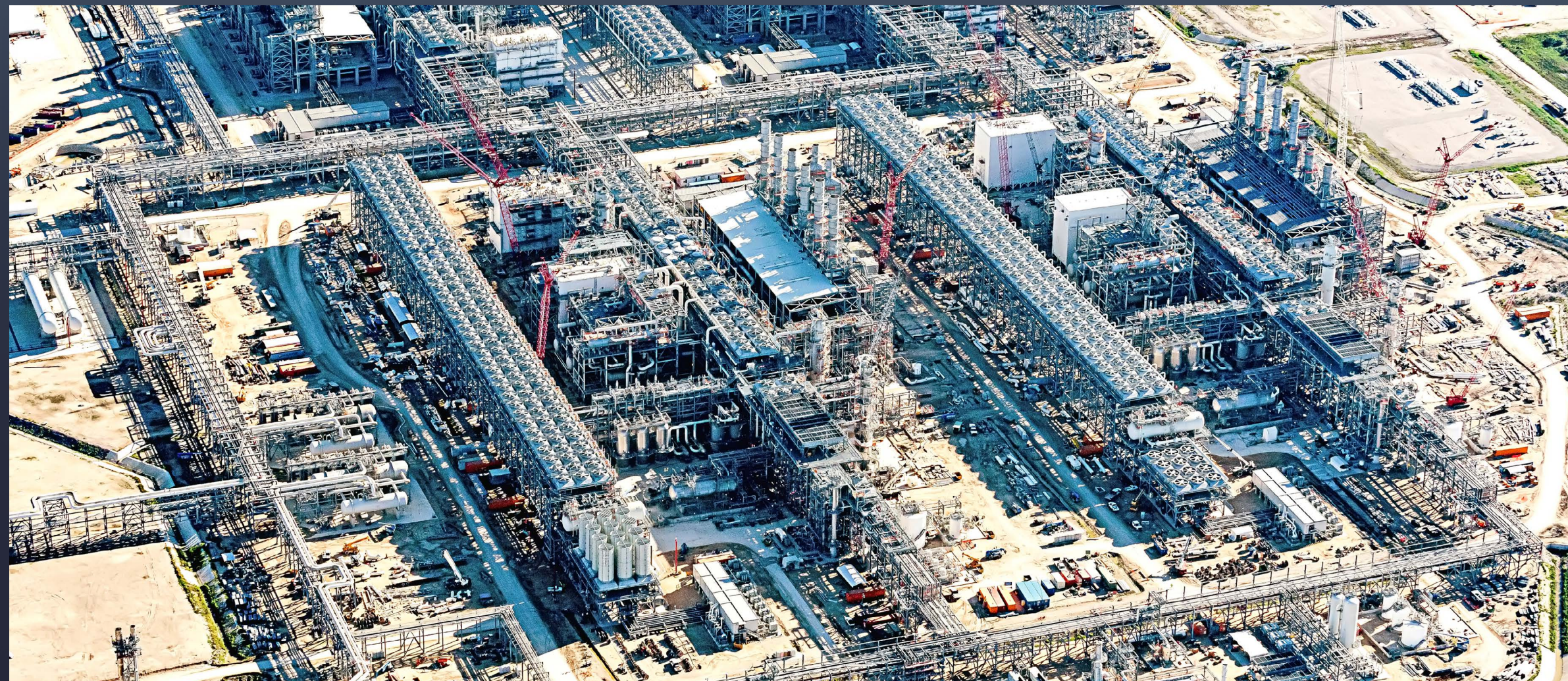

SABINE PASS LNG

USA



CORPUS CHRISTI LNG

USA



MITSUBISHI POWER M701 F4 FUEL GAS SKID



MITSUBISHI POWER FUEL GAS SKID



MITSUBISHI POWER M701 F4 FUEL GAS SKID



GENERAL ELECTRIC A160 SKID

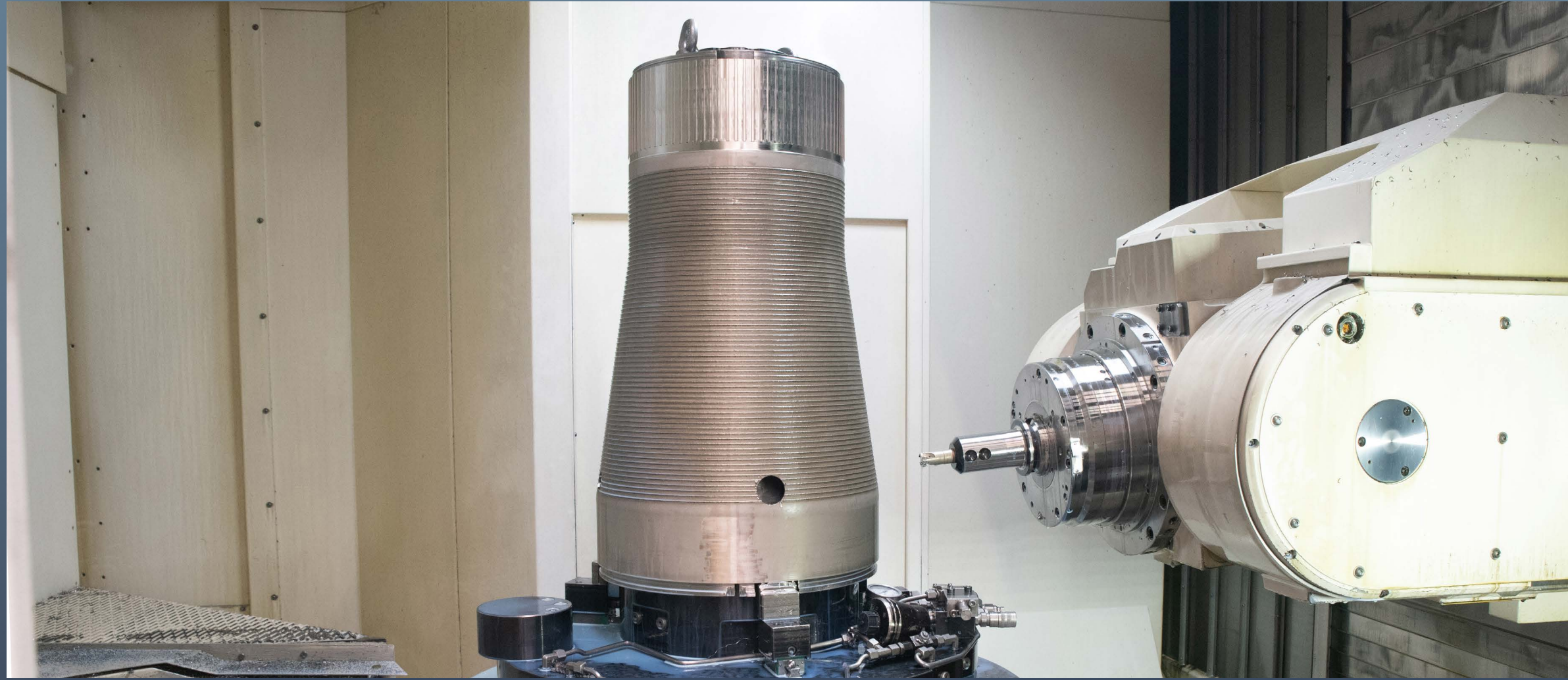

COMBUSTION LINER ASSEMBLY

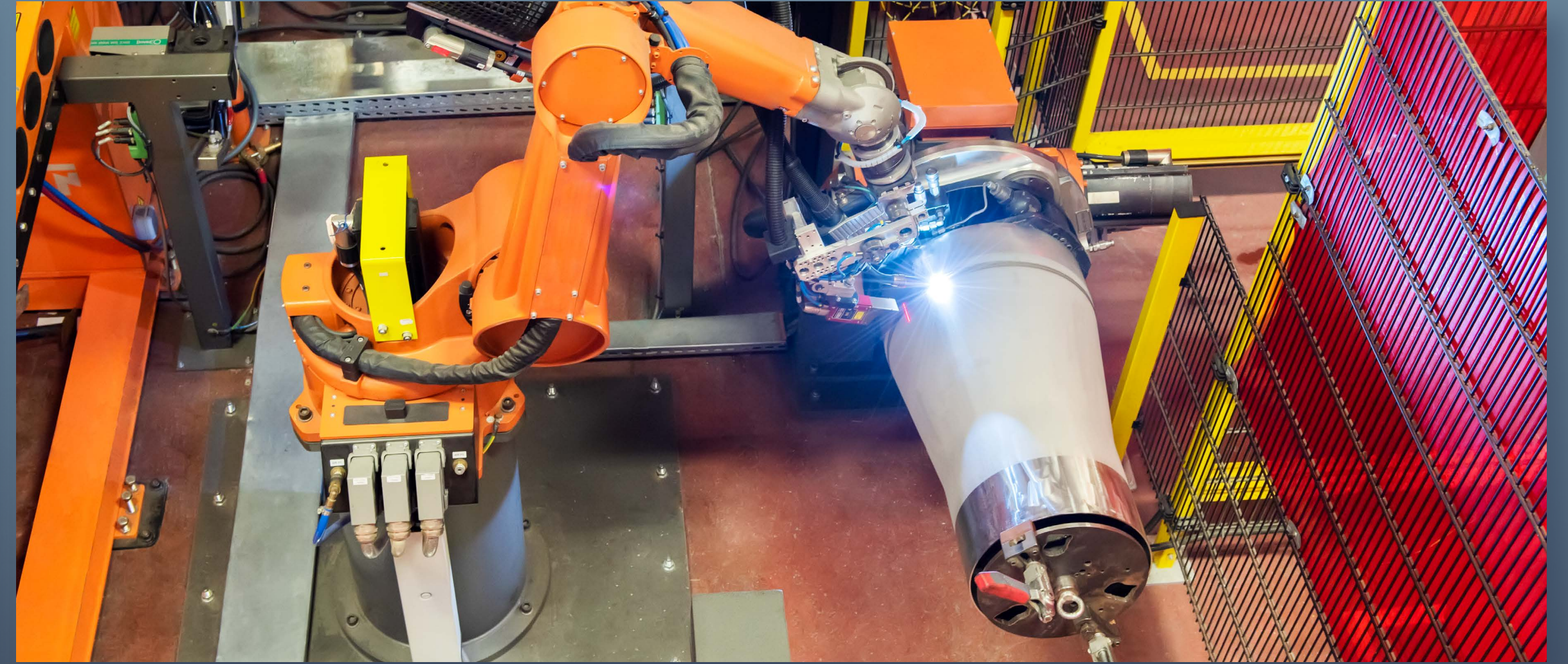

POWER - COMBUSTION COMPONENTS

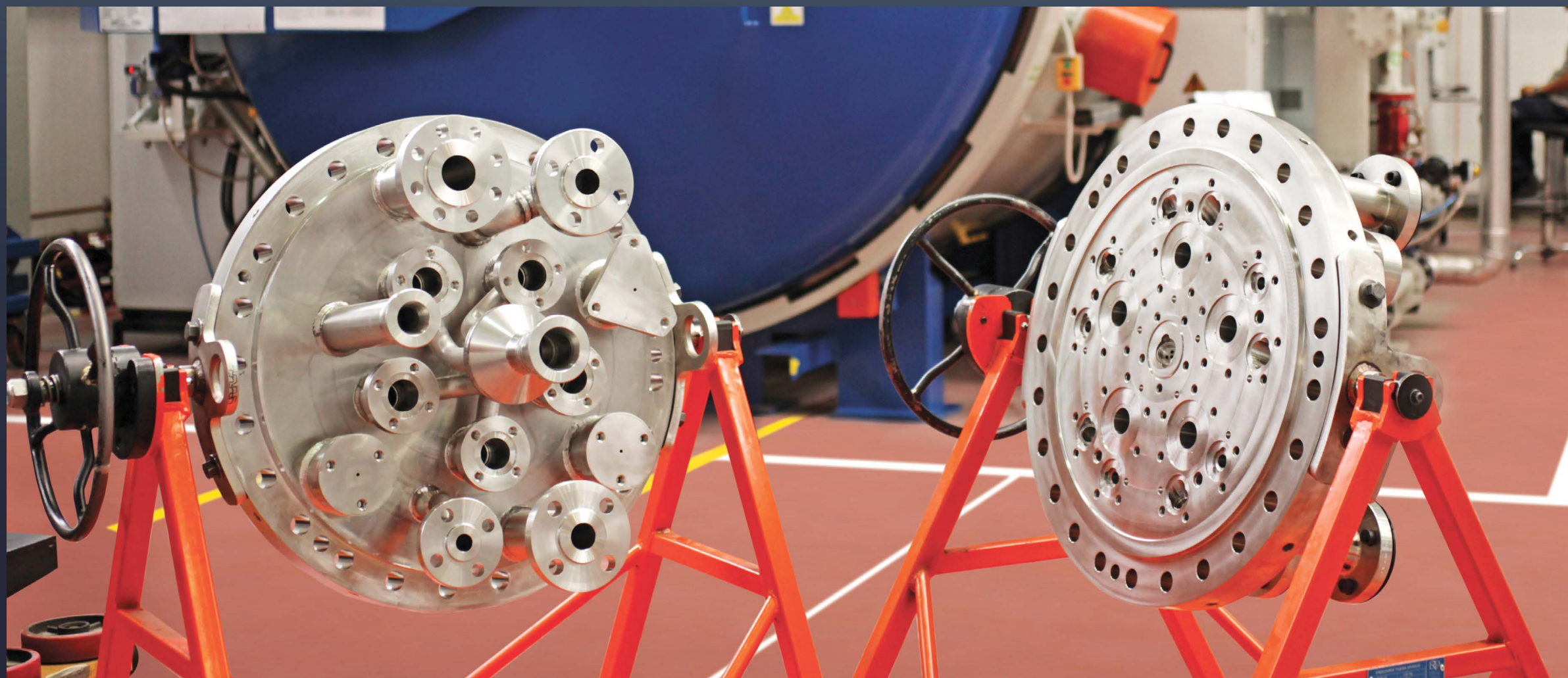

COMBUSTION END COVER ASSEMBLY



COMBUSTION OUTER CAP ASSEMBLY



HIGH PRESSURE ROTATING SEAL - CF 6



HIGH PRESSURE COMPRESSOR CONE - TRENT XWB

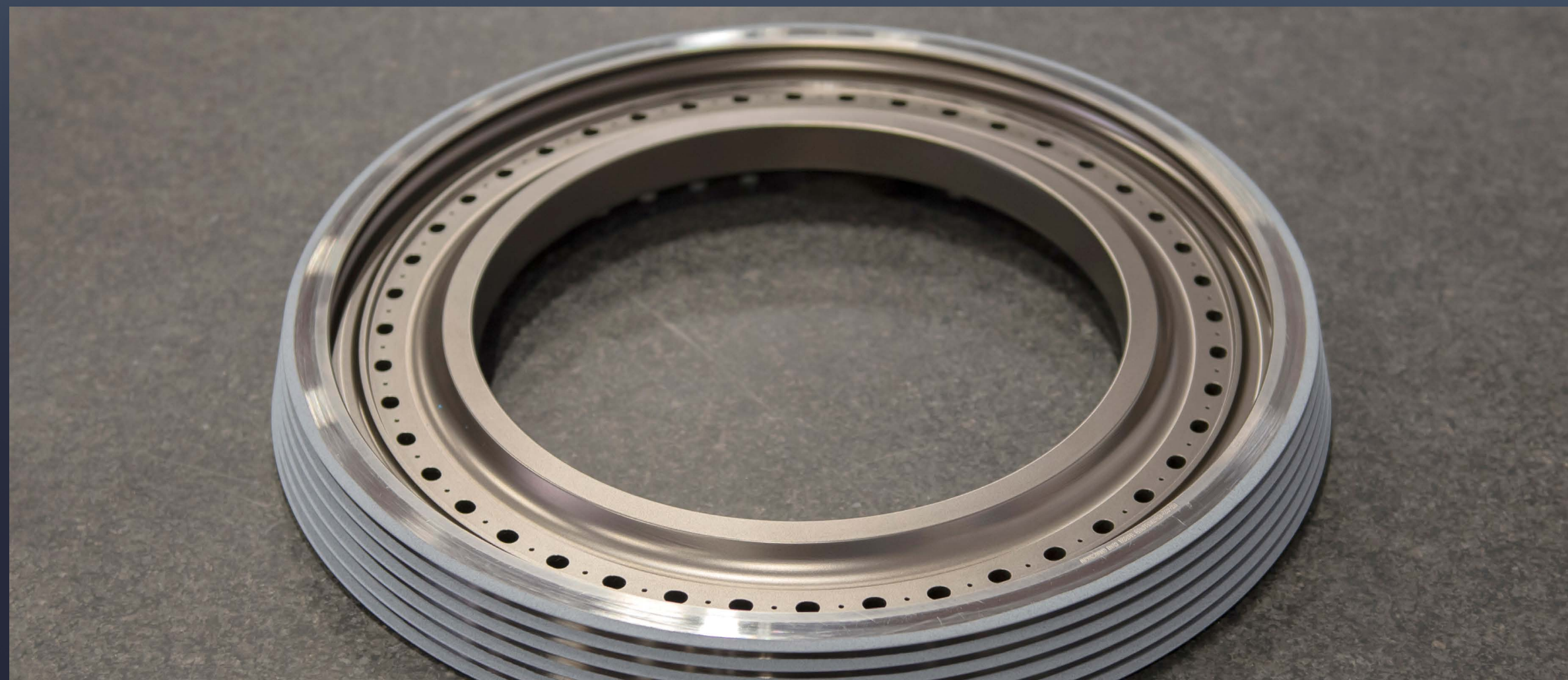

HIGH PRESSURE COMPRESSOR ROTATING SEAL



AIRCRAFT STRUCTURAL COMPONENTS

# STRUCTURAL ENGINEERING

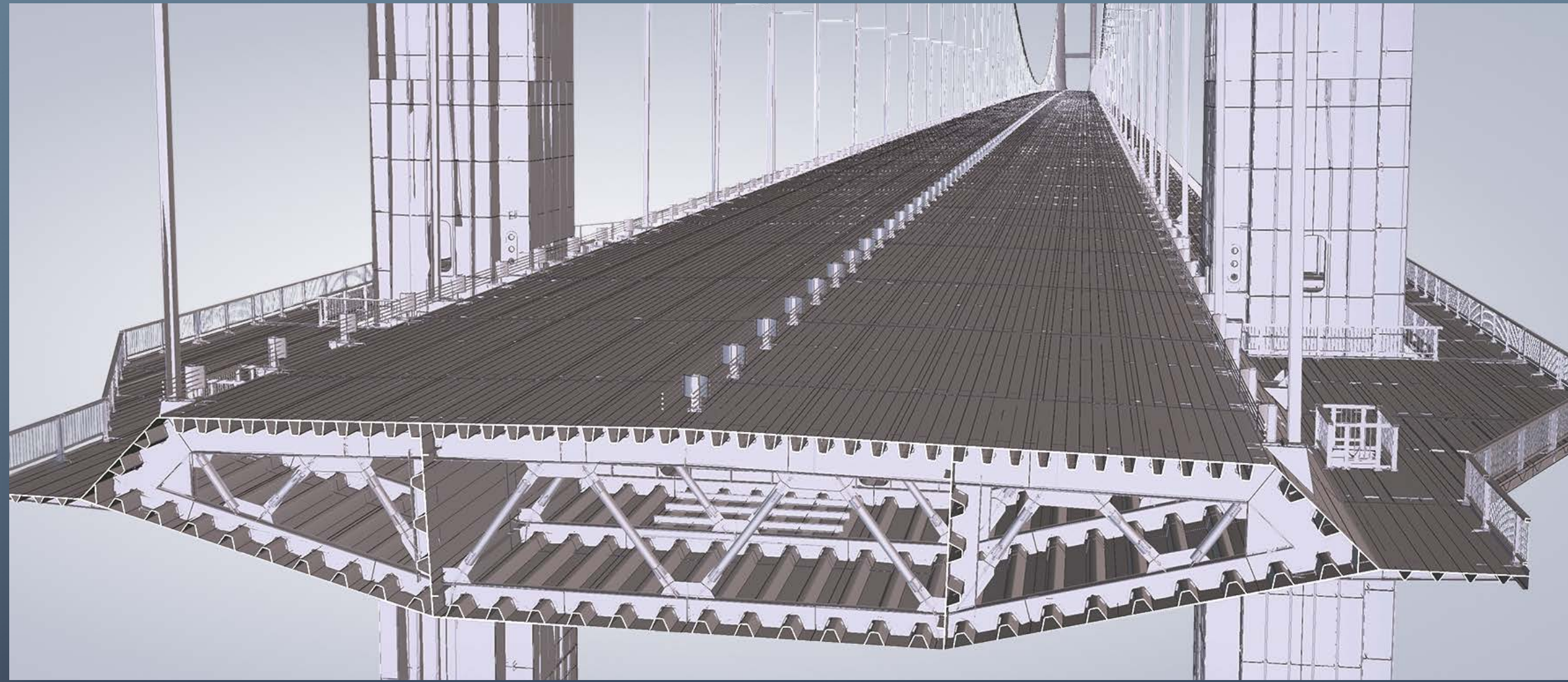

OSMANGAZI SUSPENSION BRIDGE 3D MODEL



1915 ÇANAKKALE SUSPENSION BRIDGE 3D MODEL

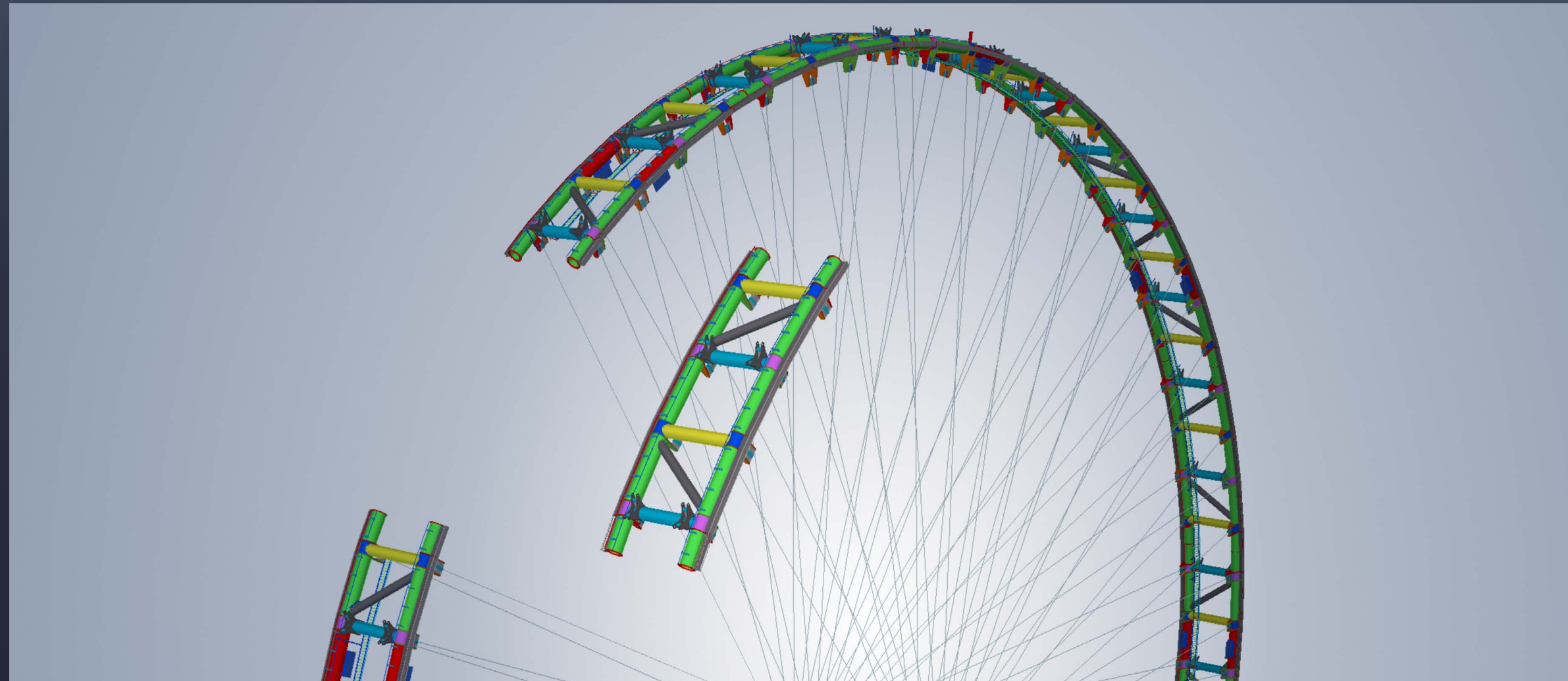

NEW YORK FERRIS WHEEL 3D MODEL



MAKKAH CLOCK TOWER 3D MODEL

# PLANT DESIGN & ENGINEERING

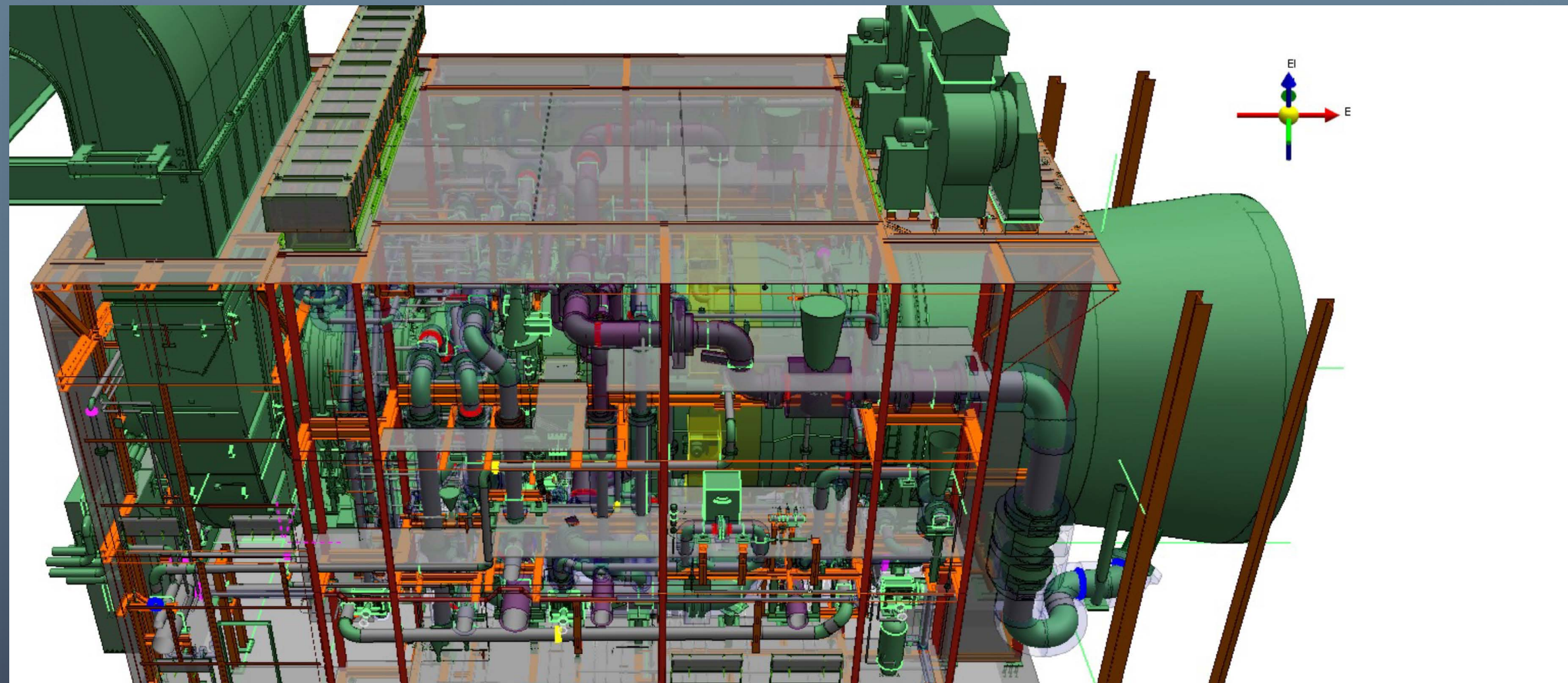

MHI GAS TURBINE MODULAR ENCLOSURE

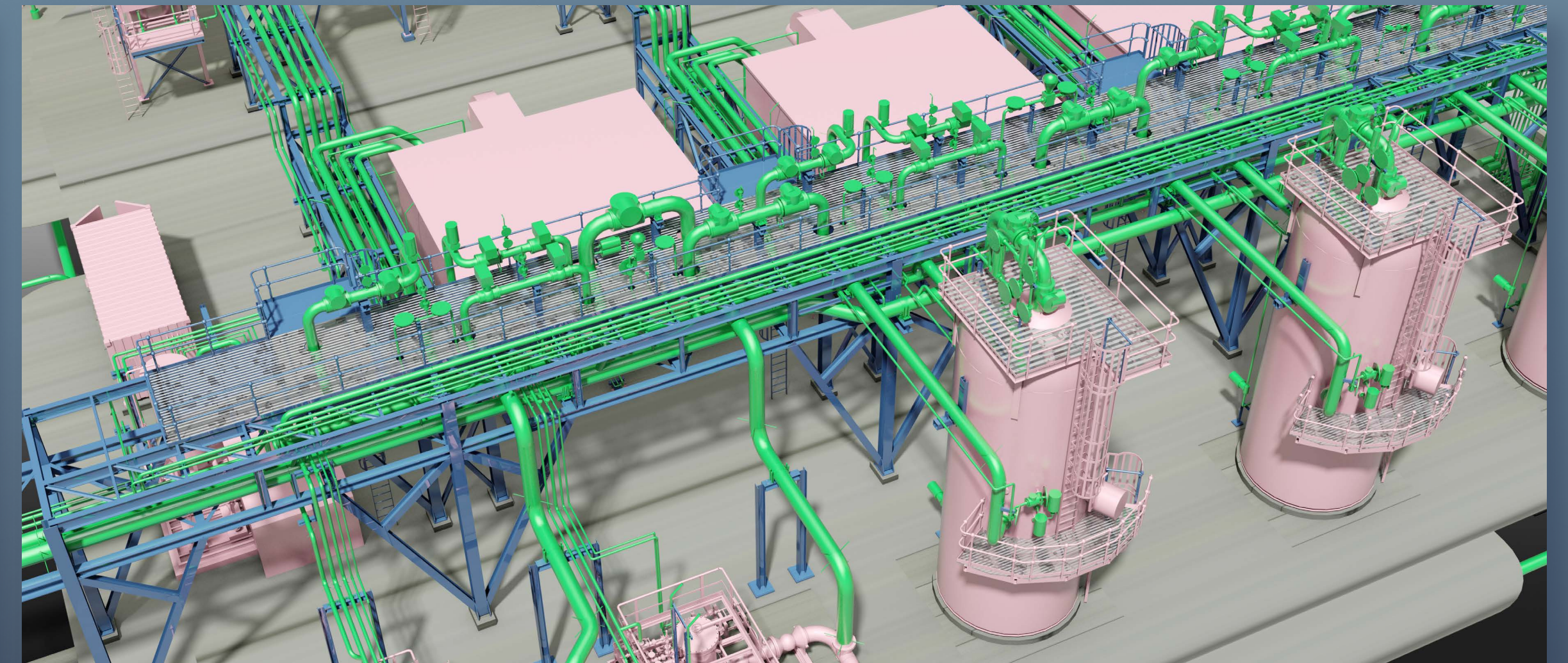

WEST QURNA-2 OILFIELD

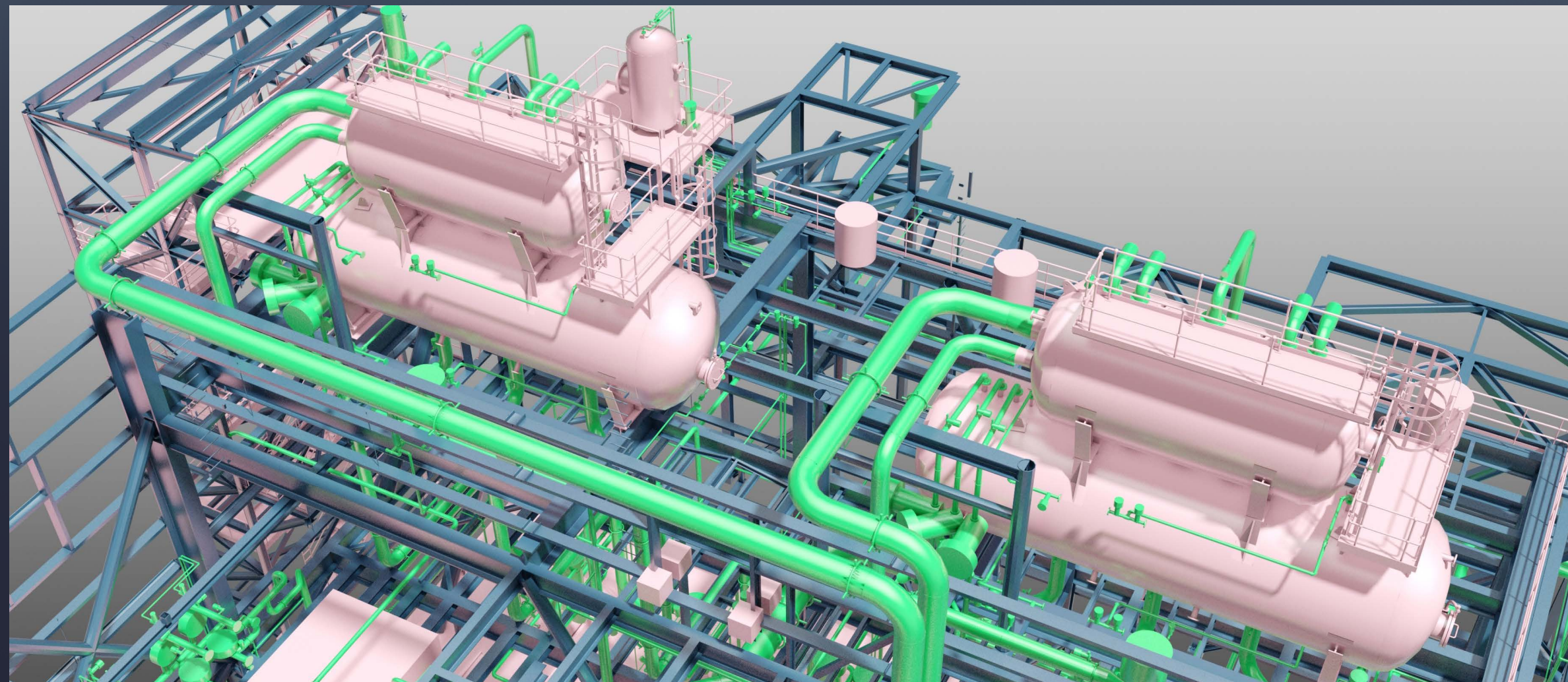

BAZYAN CCPP

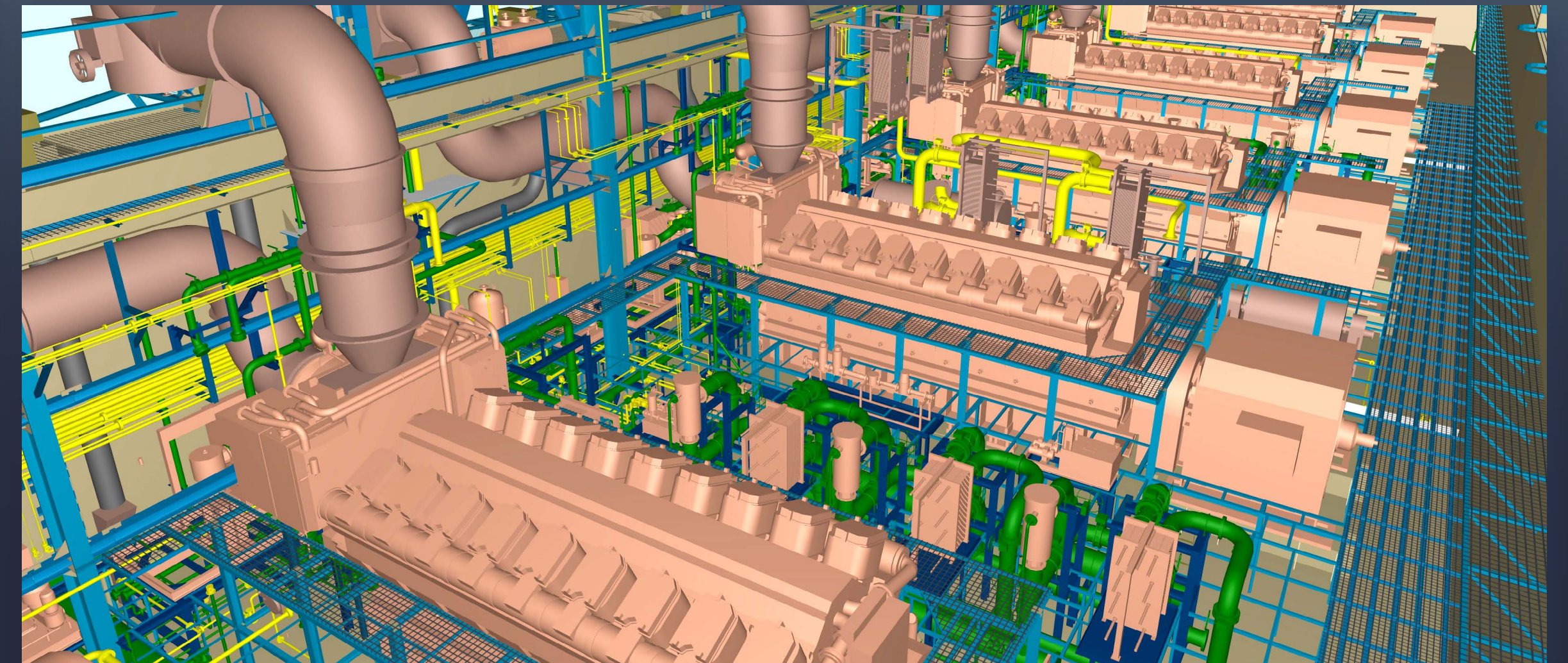

KPS-6 POWERSHIP

# FABRICATION & MACHINING

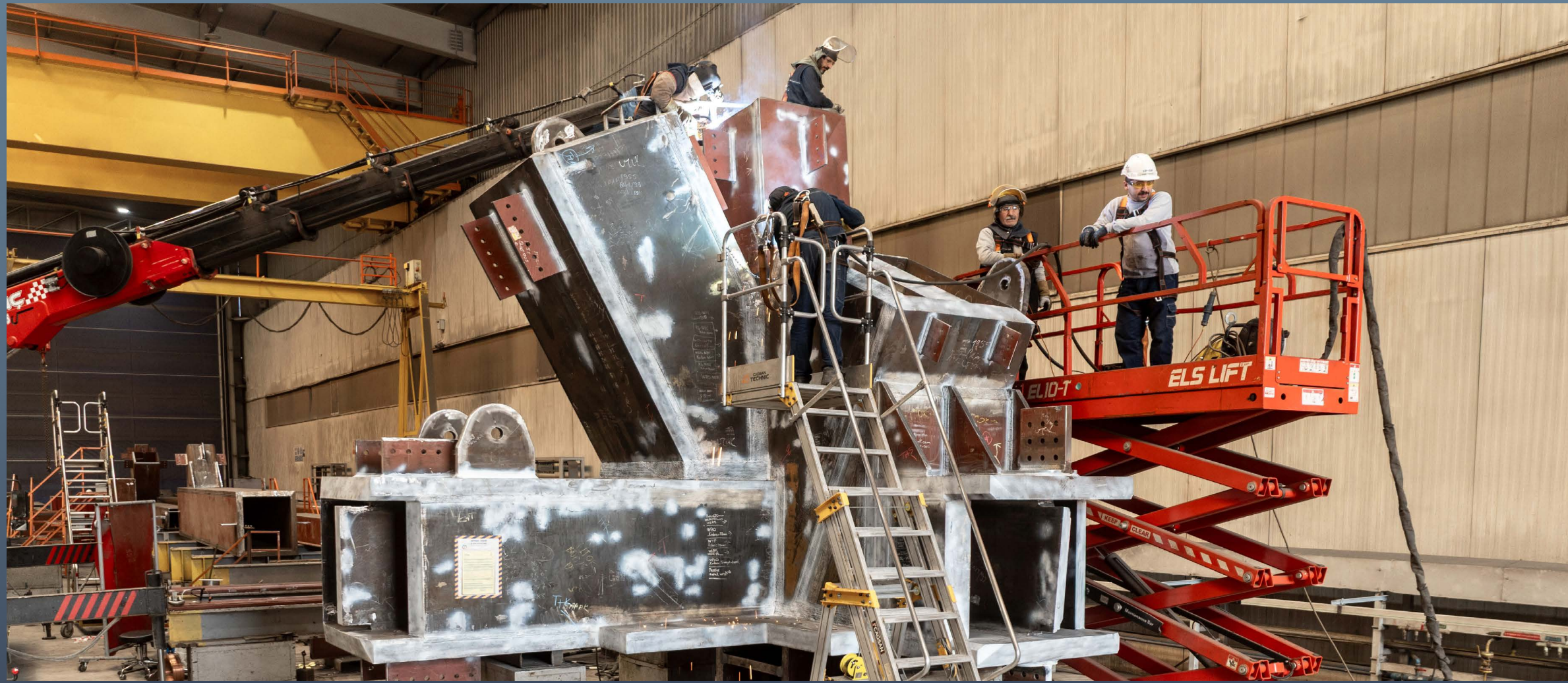

THE BLADE NODE FABRICATION



CAMP NOU STADIUM COMPRESSION RING FABRICATION

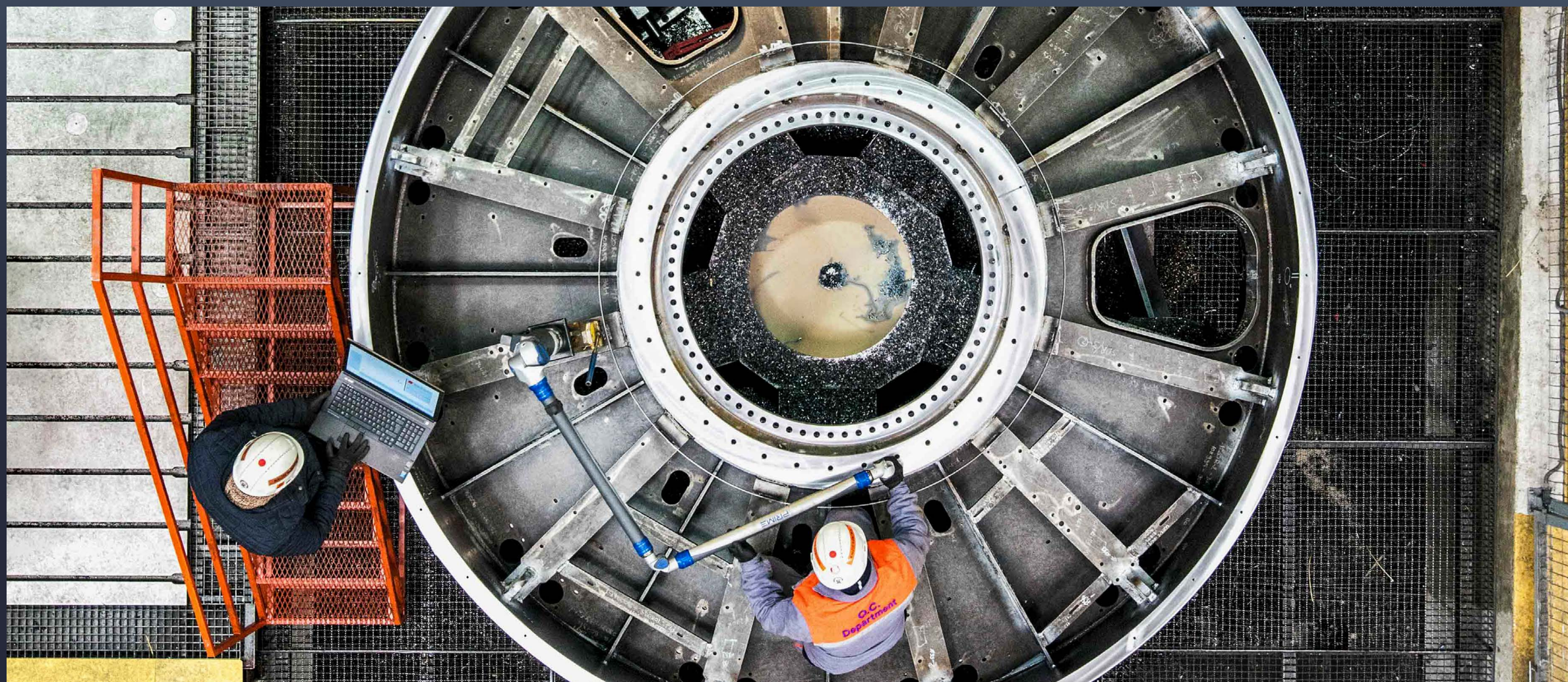

ENERCON ROTOR & STATOR

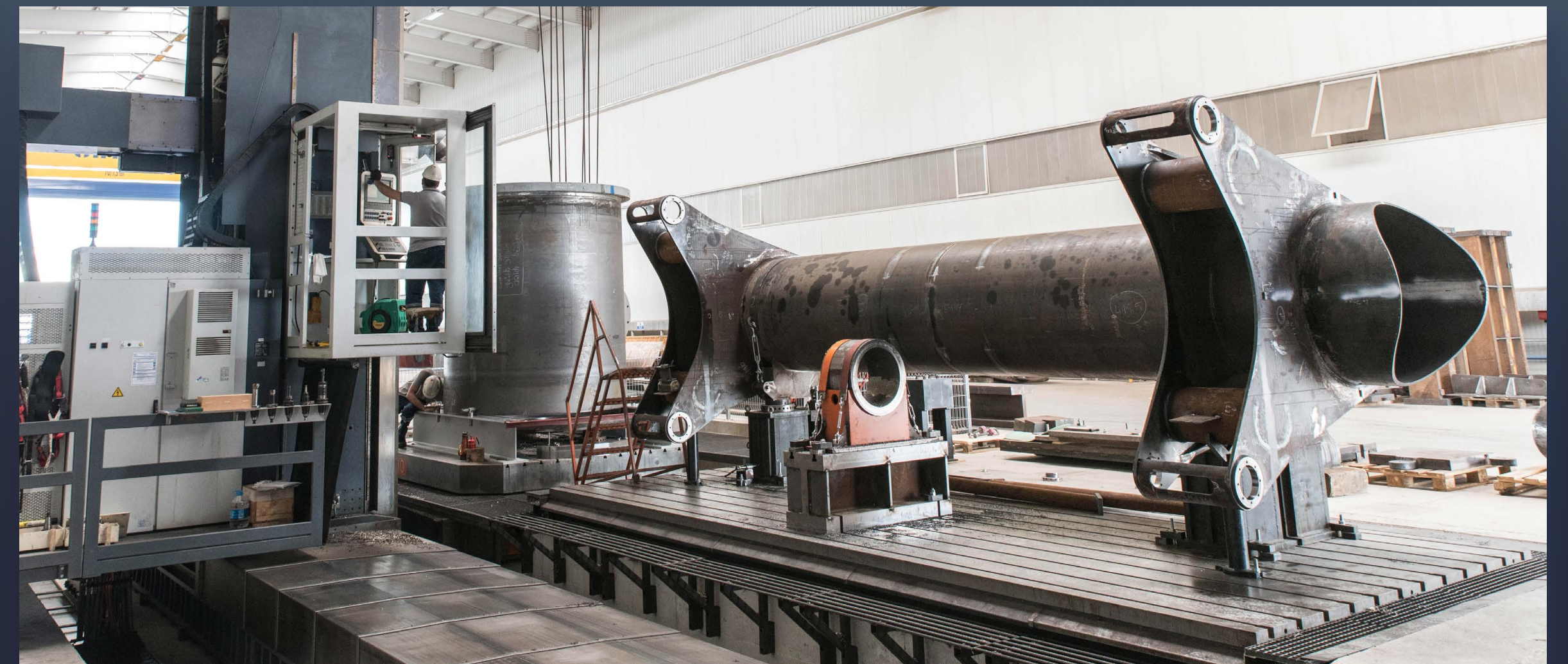

NEW YORK FERRIS WHEEL

# CERTIFICATES



EN ISO 3834-2



EN ISO 1090-2

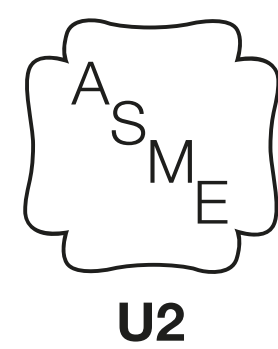
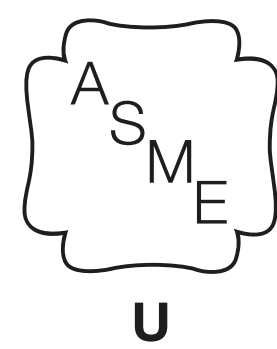
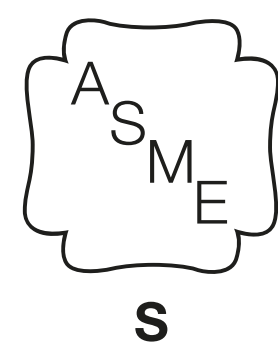
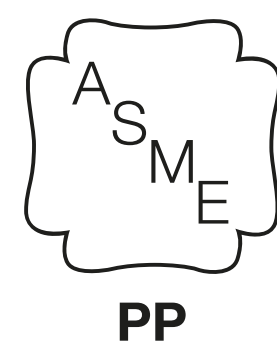
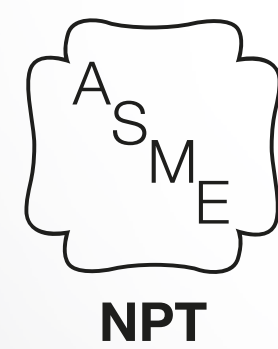
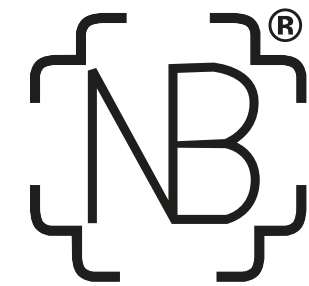



OSMANGAZİ SUSPENSION BRIDGE



STINGER SECTION PROJECT



TCO FUTURE GROWTH PROJECT



1915 ÇANAKKALE SUSPENSION BRIDGE

# LOGISTICS



ÇİMTAŞ SHIPYARD

Gölçük / Türkiye



ÇİMTAŞ STEEL

Gemlik / Türkiye



ÇİMTAŞ PIPE - ÇİMTAŞ MACHINING

Gemlik / Türkiye



ÇİMTAŞ NINGBO

Ningbo / China



GROUP COMPANIES	PRODUCTS & ABILITIES	
<p><b>cimtas   steel</b> Gemlik / Türkiye</p>	<ul style="list-style-type: none"> <li>• STRUCTURAL STEEL</li> <li>• PRESSURIZED EQUIPMENT</li> <li>• MODULARIZATION</li> </ul>	<ul style="list-style-type: none"> <li>• STEEL WIND TOWER &amp; COMPONENTS</li> <li>• STRUCTURAL ENGINEERING</li> <li>• OFFSHORE/SUBSEA STRUCTURES</li> </ul>
<p><b>cimtas   pipe</b> Gemlik / Türkiye</p>	<ul style="list-style-type: none"> <li>• SPOOL FABRICATION</li> <li>• PIPE MANUFACTURING</li> </ul>	<ul style="list-style-type: none"> <li>• FITTING MANUFACTURING</li> <li>• PLANT ENGINEERING</li> </ul>
<p><b>cimtas   shipyard</b> Kocaeli / Türkiye</p>	<ul style="list-style-type: none"> <li>• STRUCTURAL STEEL</li> <li>• FLOATING STRUCTURE</li> <li>• XL MODULARIZATION</li> </ul>	<ul style="list-style-type: none"> <li>• SHIPBUILDING</li> <li>• STEEL WIND TOWER</li> <li>• OFFSHORE/SUBSEA STRUCTURES</li> </ul>
<p><b>cimtas   ningbo</b> Ningbo / China</p>	<ul style="list-style-type: none"> <li>• SPOOL FABRICATION</li> <li>• MODULARIZATION</li> </ul>	<ul style="list-style-type: none"> <li>• SKID</li> <li>• QUICK RELEASE FLANGES</li> </ul>
<p><b>cimtas   machining</b> Gemlik / Türkiye</p>	<ul style="list-style-type: none"> <li>• HEAVY-DUTY &amp; AERODERIVATIVE GAS TURBINE COMPONENTS</li> <li>• TELECOMMUNICATION SATELLITE COMPONENTS</li> </ul>	
<p><b>cimtas</b>   ADVANCED TECHNOLOGIES &amp; SOLUTIONS INC. Seattle / U.S.A.</p>	<ul style="list-style-type: none"> <li>• TELECOMMUNICATION SATELLITE COMPONENTS</li> </ul>	

# SUSTAINABILITY

Çimtaş, along with the efforts to attain its wide-range social and economic sustainability goals, is striving to reduce its environmental footprint with all solar-powered facilities, paperless processes and responsible water & waste management approach; and by caring for an olive yard with a tree for each of its employees, a special olive kind awarded with protected designation of origin (PDO) status by the European Union at region where Çimtaş's core facilities are located.



THANK YOU  
**FOR MORE**  
[www.cimtas.com](http://www.cimtas.com)

